



Forward Curved Blower



Φ 133

Rotor Material: Aluminum Die-casting
Impeller Material: Galvanized Steel Sheet
Ingress Protection: IP44
Insulation Class: F
Bearing Type: Maintenance Free Ball Bearing

Dimensional Drawings

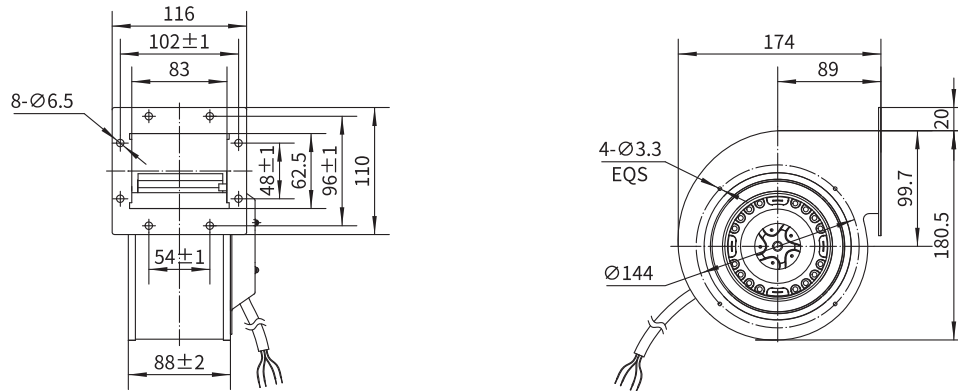

Performance Curves

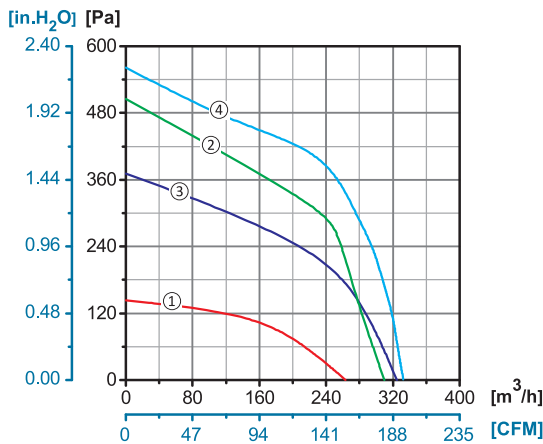

Model No.	Voltage	Frequency	Current	Power	Speed	Capacitor	Air Flow (0 Pa)	Noise	Curve	Working Temp.	Approvals
	V	Hz	A	W	RPM	µF	[m³/h]/[CFM]	dB(A)	No.	Min/Max (°C)	
YWF.F2S-133-073AA2A	110/120	60	1.11	133	2025	10	333/192	65	④	-30/+60	
YWF.F4S-133-073AA2A	110/120	60	0.56	56	1575	5	280/164	58	①	-30/+60	
YWF.F2S-133-073AA20	220/230	50	0.46	100	2090	3	330/194	65	③	-30/+60	CCC, CE
	220/230	60	0.55	120	1950	3	310/182	63	②	-30/+60	CE

